

Boilers On Demand

Neo-Gravity Hydronic Heating Appliance™

Planning & Installation Guide



Built on the Weil-McLain® Ultra (UO) Boiler with Taco® Delta-T ECM

Hydronic Distribution Technology

***Boilers On Demand* Hydronic Heating Appliances** are configurations of selected commercial components into a value-engineered product. The specifications and warranties of our component suppliers apply and supersede any of those stated or implied within our product documentation. Reference links are provided herein to our All-American Manufacturer components.

Revision E 03/10/2022

[Note: The on-line copy of this document is internally hyper-linked for user clarification.](#)

This Site Planning & Installation Guide is the exclusive property of Mercier Engineering and Boilers On Demand. It contains proprietary information, much of which is protected by USPTO Patent No. 10,690,356, Trademark and Copyright Laws of the United States of America and Canada. None of its contents may be reproduced in part or in whole or divulged to another party without the expressed and written permission of Mercier Engineering, detailing the specific content of this material and to whom its sharing is authorized.

Table of Contents

I. Introduction	Page 3
II. Planning	Page 5
1. Review your State and Local Codes and Regulations.	Page 5
2. Determine your system size and configuration.	Page 6
3. Qualify your site for delivery and positioning.	Page 8
III. Product Description	Page 9
IV. Installation	Page 14
1. Exhausting.	Page 14
2. Pre-Assembled Manifolds	Page 16
3. Piping Planning & Installation	Page 18
4. On-Site Wiring Installation	Page 20
5. Fuel Line Installation	Page 21
6. Post-Assembly Insulation (Optional)	Page 22
V. Start-up and Operation	Page 23

Quick-Reference Links:

[Weil-McLain Ultra Oil Brochure](#)

[Weil-McLain Ultra Oil Manual](#)

[Weil-McLain Beckett NX Instruction Manual](#)

[Taco® VT2218 Delta-T ECM Variable Speed Circulator](#)

[Taco “Zone Sentry” Zone Valves](#)

I. Introduction:

This Planning & Installation Guide is written to accommodate both new and replacement installations of our Neo-Gravity Hydronic (FHW) Heating Appliances™ utilizing Delta-T (Δ -T) Differential Temperature Management and ECM (Electronically Commutated Motor) Technologies. Our pre-built appliance configurations provide a compact, efficient and cost-effective alternative to contemporary equipment installations and methods. Accommodated site-specific variations in boiler, piping & utilities are noted.

Where applicable we preface instructions and comments that apply specifically to a **new install** with **NEW** and to a **replacement install** with **REPL**. Please make note of these. Otherwise content applies to both end uses.

Our Delta-T ECM Appliances are built upon a “high-mass” (heavy) cast-iron boiler that requires particular attention to its placement considerations and access points. They are also “pressure-fired” and thus negate a chimney, if alternative placement and a “Direct Vent Option” installation costs justify.

Our “high-mass” boiler configuration can be interchangeably fired with **OIL** or **GAS** (Natural or Propane) Burners, making it also the first “universal” appliance. Fuel-specific notes and instructions herein are noted as **OIL** or **GAS**, as they may apply.

We present these and other system attributes to you as an encouragement to “think out of the box”, as they say. In so doing you, the client may be able to envision an opportunity to take advantage of these attributes, whether designing your new dream home or getting around whatever nuisances or desires you have noted in your present home. Make note of these and qualify them to your particular application.

Planning and Installation Guide content is presented as it would be to a homeowner or Do-It-Yourselfer (DIY), recognizing that contractors, skilled tradesmen and architects are mutual beneficiaries of our products. Thus clarity trumps seemingly excess detail.

All-American-Made Components are purposefully utilized in our products. They are selected, configured and assembled into a value-engineered package, drawing from our sixty-plus years of concurrent participation in both the heating trades and “high-tech” manufacturing process development. Our further processing and assembly methods convert these into a sound and performing product.

Acknowledging that there are many commendable heating equipment suppliers, both domestic and foreign, our hydronic heating appliances are specifically configured for **best value and performance only, by design!**

Our “Appliance” approach accommodates a variety of application variations. Specifically:

1. Three (3) boiler capacities are available to suit your application.
2. Distribution (number of zones and sizes) is specifically configured to your application. Provisions for additional zone expansion(s) are provided within our design.
3. Our Appliance can be optionally plumbed at boiler supply and return points to accommodate future parallel heat source(s) such as solid fuel (wood/coal) boilers, solar, etc. or an Indirect Water Heater.
4. The integration of an Indirect Water Heater (IWH) to generate Domestic Hot Water (DHW) most efficiently is highly recommended. An “On-Off” Selector Switch is provided to efficiently manage IWH usage demands. It can be further extended to “program” your IWH with cycle timers, etc. for even further energy utilization efficiencies.
5. Three (3) interchangeable fuel powering options are available, #2 Heating Oil (Standard), Natural or Propane Gas (Optional at a premium).

Throughout this Guide we refer to our extensive Blog Library on our website for clarification or additional subject detail. These are tagged as **BLOG**.

II. Planning:

Appliance Planning requires three (3) steps that must be executed in successive order:

1. Review your State, Local Codes and Regulations.
2. Determine your system size and configuration.
3. Qualify your site for delivery, positioning and installation.

Refer to the [Weil-McLain Ultra Oil Manual](#) for additional installation detail.

Item 1. Review your State, Local Codes and Regulations.

Heating System Codes are typically multi-leveled, the State Code predominating with underlying Local Codes and occasional Jurisdiction Codes following. Additionally there may be applicable State and Municipal Technician Licensing Requirements. You must ascertain these specifically applicable to your locality.

Pay particular attention to the **exhausting, placement and fire suppression** requirements. They will determine both the physical placement options and supporting construction detail. More specifically:

1. **Exhausting:** The default means of exhausting is a chimney, but the option of a through-wall [Field FDVS Direct Vent System](#) is available for the Weil-McLain UO Series FHW Boiler using the Beckett NX Pressure-fired Burner.
Be careful however in selecting your kit venting point! The common error (and Code Violation) is to exit too low to the exterior and inviting snow buildup that inhibits exhausting. The usual requirement is 12” to 18” above the anticipated seasonal snow cover. Check your Codes on this point in particular!
2. **Placement:** The boiler should be placed as closely as practical to its exhausting point, whether utilizing a chimney or a direct venting location. The penalty is an increased cost and maintenance factor on flue piping. Hydronic (FHW) boiler location is very flexible by design, but practically it should be reasonably centrally located to avoid excessive distribution (zone) piping and utilize the appliance’s natural convection economies upon utilities and operation.
3. **Fire Suppression:** Fire Codes typically require fire suppression or propagation means and devices. Along with the electrical and fuel cutoff switches and valves located above the boiler, at the burner and at the oil barrel (if applicable) there is typically a requirement of a one-hour rated drywall or fireboard above the boiler area. Some codes offer the option of a sprinkler head placed over the burner, a reasonable alternative to consider.

REPL Note: Oil tank position relative to boiler (burner) location can become a factor. Code tank-to-burner proximity distances can vary from a minimum of five (5) feet or more. A usual option is to construct a fire barrier (wall) in closer proximities. Check your specific code(s).

Item 2. Determine your system size and configuration.

Determining your Hydronic Heating Appliance requirements requires only two (2) steps:

1. Calculate your heat loss requirement (boiler size).
2. Detail your heating and domestic hot water requirements (no. of zones, sizes).

Note: Our Delta-T ECM Appliance by design and as delivered contains all of the FHW system components excepting the fuel source elements (fuel tank and/or line(s)), flue pipe (exhausting) and the building heat distribution (baseboard, heaters or radiators, piping and controlling thermostats). It remains upon placement to attach or install these components along with a system domestic cold water source and extending piping to the various radiation elements (zones).

1. Calculate your heat loss requirement (boiler size). This measurement is critical to a successful installation. Refer to our **BLOGS** on this subject and in particular to those related to using a **Heat Loss Calculator**.

You must use a Heat Loss Calculator to accurately determine your total heat demand and hence correctly size your boiler (KBTU/HR). Note this value.

Note: Be sure to use the maximum sustainable low temperature anticipated for your area (ΔT). Ex.: 70°F interior to -20°F exterior = 90°F ΔT design factor.

NEW: Your designer data may be available or a Heat Loss Factor (BTU/Sq.Ft.) may be adequate for your new construction type.

REPL: You CANNOT typically use your existing boiler nameplate data to size your new system! There are two (2) reasons for this:

- a. Your boiler may have been over-sized by practice upon original installation.
 - b. Energy efficiency improvements to your home will have effectively made your boiler larger in proportion to your current requirements.
 - c. Additionally, heated floor space addition(s), whether external or internal expansions, will also change your heating load demand.
2. Detail your heating and domestic hot water requirements. For our system definition purposes you must answer the following questions:
 - a. Is your boiler located on the lowest heating level, basement or main level, and are there heating requirements below this level? Note that if **all** heating is on the same level as the boiler, a low supply & return option is available.
 - b. Do you currently or plan to connect another boiler (coal, wood, etc., internal or external) to your primary FHW heating system? If yes, we optionally provide

- piping points at the supply & return for efficient connection. These fittings we typically plug but may be valved at your option. Advise your preference.
- Do you currently or plan to connect an [Indirect Water Heater](#) (IWH) to your system for Domestic Hot Water (DHW) generation? If yes, we provide specific piping points with Zone-Valve Supply and a Ball-Valve Return as delivered. These points are similarly positioned as an extended boiler in 2.a. above.
 - Indicate the number of heating zones on the same level as the boiler. These would include basement and lower living zones as applicable. Note that a basement or garage area [Unit Heater](#) typically is piped overhead and thus included in the “above the boiler” category.
 - Indicate the number of heating zones above the boiler. This includes all those on the main and upper levels. Add any Unit Heater zones as defined in 2.d.
 - Transfer the data from Item 2. Nos. 1. & 2.a. to 2.e. above to define your Model Number. (See Fig. 1) Use this number for quotation on our website and reference for further transactions.

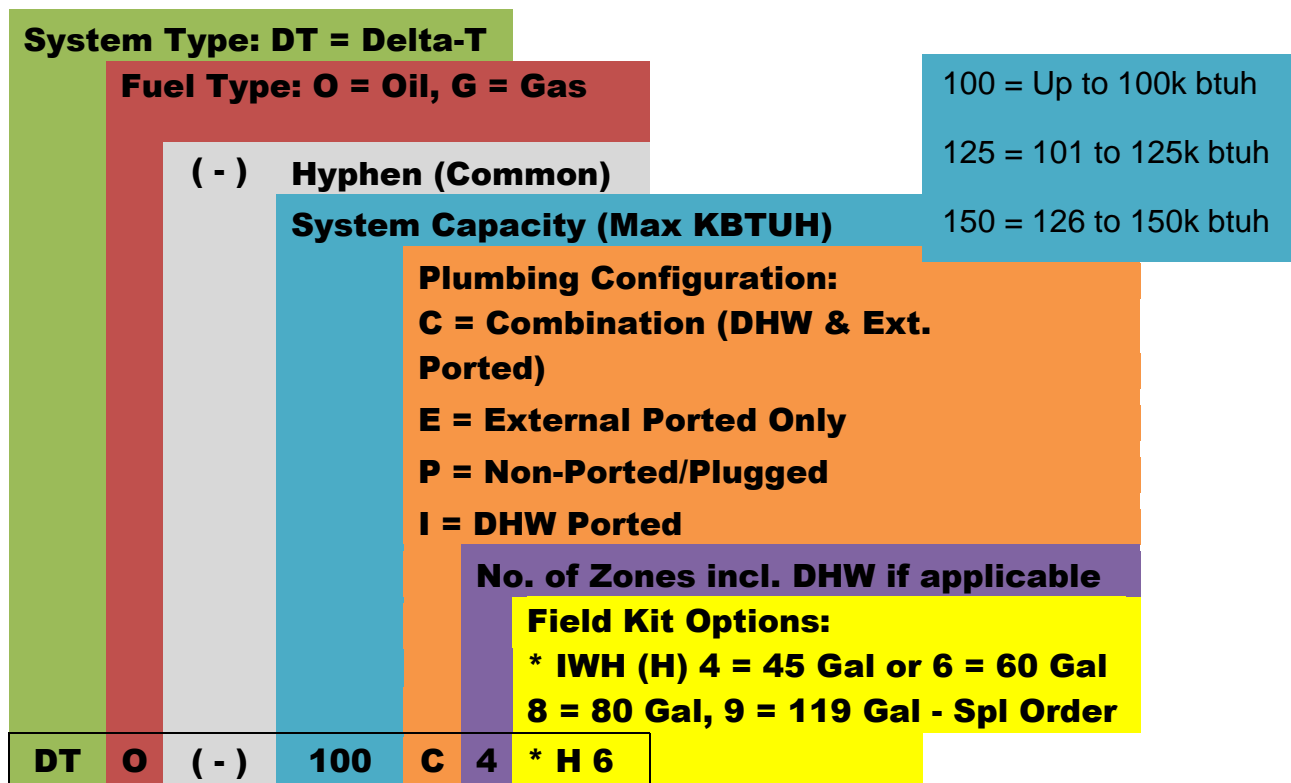

Fig. 1

Examples:

- DTO-100P2:** Delta-T, Oil-Fired, 100,000BTU Max, 2-Zones (Heat-Only Application)
- DTO-125I4-H6:** Delta-T, Oil-Fired, 125,000BTU Max, DHW Ported/Valved, 4-Zones w/ Indirect Water Heater (detached option)
- DTO-150C6:** Delta-T, Oil-Fired, 150,000BTU Max, DHW/Valved/Ext. Ports, 6-Zones

Item 3. Qualify your site for delivery and positioning.

Our Neo-Gravity Hydronic Heating Appliance™ is a modular product made up of several sub-assemblies and loose-piece components that are configured at the point-of-use. Their characteristics vary widely in size, packaging and handling methods. They are briefly:

1. A pre-plumbed & wired [Weil-McLain UO Boiler](#) assembly weighing between 675 and 925 lbs. It handles on a commercial appliance 24" wide dolly with "Big Wheels" using a special boiler adapter. Requires 2-3 men to handle.
2. A Beckett NX **OIL** Burner or a Carlin EZ PRO **GAS** Burner in its supplier carton. 1 man handles.
3. A Supply Manifold Assembly to suit the application. 1 man handles.
4. A [Hydronic Expansion Tank](#) in its factory carton. 1 man handles.
5. A Return Manifold Assembly to suit the application. 1 man handles.
6. A loose-piece and documentation package. 1 man handles.

Refer to the [Weil-McLain Ultra Oil Manual](#), **Page 38** for Boiler Dimensions. To determine positioning in your application look at the Top view and use the applicable 22-1/16" width dimension from the Front view. Similarly use the overall depth dimension for your system and **ADD 11" min. to 15"** behind the boiler for exhausting (flue pipe) for a total depth dimension. This is the "footprint" that you must qualify for placement.

There are placement options, however. The boiler requires minimal to no access on either side for service. (*W/M Manual, Page 8.*) You can turn the boiler 90° and place it along a wall near the exhaust, exposing all the rear plumbing. This is favorable if you have or are installing an Indirect Water Heater. "Back-to-back" placement along a wall minimizes piping, space and increases efficiency. We refer to this as "close-coupling".

The plumbed base boiler module as delivered is approx. 46-1/2" high. Assembling the supply and return manifolds in place increases this dimension to approx. 78", as used. All plumbing and exhaust is within the 11-15" x 22-1/16" nominal area behind the boiler. The stacks & laterals contain the zone supply and return valves, resp'y. They exit at approx. 72" height. The supply lateral can be freely rotated up to 215° (est.) and the return a full 360° for plumbing extension efficiency at your site. (See the "lateral" detail description in the following section.)

A shorter height configuration (66" O.A.) is available at order, but requires DHW Valve branching rotation adjustment.

Note: Further Appliance "shortening" requires repositioning of the suspended tank or the substitution of a floor expansion tank with space. Contact us for design options.

III. Product Description:

The following further product detail is presented with comments and notes to provide the reader with a greater scope in planning their installation. The primary reference document is the [Weil-McLain Ultra Oil Manual](#) with its **Pages** noted as applicable. Initial reference to the **Neo-Gravity Hydronic Heating Appliance™ Product Overview** on this site will also be helpful.

The Weil-McLain UO Series boiler has some advantageous design features that should be qualified immediately.

1. It comes with and we always install the machine leveler pads under the boiler. (See **Manual, Page 3, Item 22.**) Features:
 - a. Floor can be rough and out-of-level by over 1" to 1-1/2" without concern.
 - b. Levels and locks readily without shims.
 - c. At maximum leveler extension the boiler can be submersed in up to about 6" of water without incident. Substantially rids the need for concrete pads and cement blocks that were typically used, and you can clean under it!
NOTE: This does not substitute for a solid floor or a weight spreader. After all, this is still a very heavy, high-mass boiler. (It is the heaviest triple-pass cast-iron boiler for its capacity on the market --- by far!)
2. Minimal clearances are required for installation. (See **Manual, Page 8.**) Service access is required only on the front, rear and top of the boiler.
 - a. Either side of the boiler (L or R) can be placed within 2" of a wall or chimney, allowing turning the boiler up to 90° from the usual. (See also prior comments in Planning Section, Item 3 above.)
 - b. The hinged burner is also field reversible from the factory supplied RH swing. However, RH is usually preferable for ease of technician access and service.
3. The Beckett NX **OIL** or Carlin EZ-PRO **GAS** Burner supplied is a "pressure-fired" device, i.e. it pushes combusted gases out of the boiler.
 - a. It will accommodate poor & erratic chimney draft conditions.
 - b. An optional [Field FDVS Direct Vent System](#) is also available, eliminating the need for a chimney altogether. Check your Local Codes for installation details however.

The [Taco® VT2218 00e Series](#) Delta-T ECM Circulator supplied is matched specifically to our appliance operation. Taco has referenced our field data in making design improvements to their current product. It is integrated as follows:

1. Circulator is mounted just above the boiler chassis on the center-rear vertical supply line.

2. A [Circulator Flange Drain Valve](#) is also provided for rapid service isolation & repair.
3. Circulator is hard-wired into the boiler chassis module.
4. It is operated solely in the “DELTA-T” mode in our application, despite having five (5) selectable modes, reflecting its technical sophistication.
5. The two (2) (ΔT) Temperature Sensors are positioned externally near the boiler supply and return exits to finitely manage system circulation.
6. The Delta-T (ΔT) temperature differential is default preset at 20°F for general system operation. This setting is readily field-adjustable to further tune system operation, if necessary.

General Appliance Construction:

1. **A very high-mass, cast-iron, wet-base, heat-only boiler is the building block of our heating appliance.** This enables an enhanced hydronic convection heating level unachievable with any other near-boiler piping configuration.
2. **Near-boiler piping and valving is of all black & malleable iron, brass and bronze construction.** Components are very compactly packaged for optimized hydronic and energy performance and ease of maintenance.
3. It is a “free-standing” appliance. Selective heavy duty pipe nipples & fittings are employed at high stress points for maximum durability and structural integrity.
4. Rigid piping yokes are installed between the supply and return risers to preclude joint movement during transit, installation and subsequent use.
5. All water service and zone piping points are **IPS** (internal pipe threaded) for maximum installation flexibility. Interconnection method(s) per your option.
6. All hydronic jointing is “double-doped” using ["Blue Monster" Teflon™ Tape](#) and [Rectorseal Tru-Blu™ Joint Compound](#). **No leaks!** Piping joints can also be moderately adjusted (rotated) during appliance installation as desirable.

The “Boiler Module” is a fully assembled, piped and power distribution wired base assembly to which all attendant fuel and distribution functions attach.

The Supply Manifold is a pre-built assembly consisting of:

1. A black-iron stack, ell-piped riser and lateral “Compact Steel Hydronic Header” configured to the application.
2. Black-iron tee(s) for extensions, DHW and Heating Zones as required.
3. An integral [Air Eliminator](#) on the lateral for system venting.
4. A teed [Pressure Regulator Assembly](#) below the Air Eliminator.
5. Separate [Hydronic Expansion Tank](#). (Assembled on site.)
6. Pre-assembled, piped and wired [Taco® Zone Sentry Valves](#) for zones and DHW, as applicable.

7. A Taco [Circulator Freedom Flange Valve](#) that mates with the [Taco® VT2218 Circulator](#) top flange on the Boiler Assembly.
8. The 4-wire zone valve harness terminates to the Boiler Assembly Terminal Block.

The Return Manifold is a pre-built assembly consisting of:

1. A black-iron stack, ell-piped riser and lateral “Compact Steel Hydronic Header” configured to the application.
2. Individual zone return shutoff valves, as required.
3. A union half to couple to boiler return riser.
4. A Swing-Clamp Yoke Assembly that secures the Supply & Return Manifold pairing at final assembly.

The “Compact Steel Hydronic Header” (Fig.2) noted above is our proprietary device having unique attributes complimenting Appliance design and functionality, namely:

1. Fully integral ASTM A53 welded steel pipe construction.
2. Full hydronic zone valve compaction (2-3/4” Centerlines per Taco® Engineering). Also works well with hydronic ball (return) valves.
3. Flow proportioned to enhance convection.
4. Available with 2 to 5 branches. Threaded nipple construction allows both “ganging” with couplings, tees, etc. and for future zone expansion.
5. Fitting rotation permits Taco® Zone Sentry Valve “Status Lamps” (Green LED’s) to be optimally located for visibility, eliminating the need for a Relay/Valve Panel and wiring. It also provides greater diagnostic functionality.

ZVH334-11

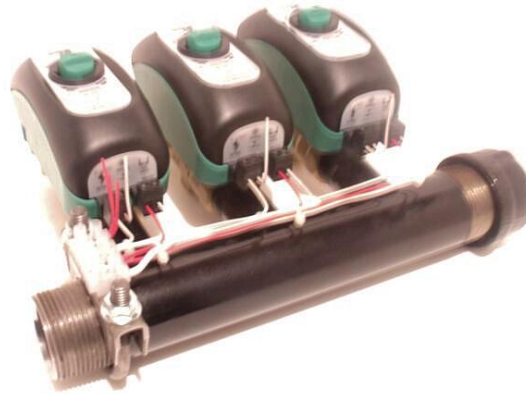

334-11

ZONE VALVE HEADER

Fig. 2 - Detail will vary from pictorial.

The Indirect Water Heater (H Option) is factory pre-assembled with DHW pressure relief & drain fittings. Further assembled and kitted as follows:

1. Boiler loop (Class 150) IPS upper & lower supply fittings with lower drain valve assembled.
2. DHW Hot & Cold Taps have (2) IPS Ball Valves assembled. Field extend as appropriate.
3. A SPST OFF-ON Switch, mounted in IWH Aquastat Access Panel. Permits user-selective appliance operation as desirable.
4. Field Assembled Pressure Relief (Copper) Drop Fittings as follows:
 - a. Drop Line, 3/4" x 48" (Copper)
 - b. Lateral Line, 3/4" x 10" (Copper)
 - c. 3/4" CMA & 90° EI Fittings
5. Amtrol Thermal Expansion Tank (Loose Piece, to suit).

An Appliance Accessory Carton consisting of:

1. Pressure relief valve drop (1/2" x 24" B.I. Pipe)
2. Factory Accessory Carton (Barometric damper and misc. hardware).
3. Documentation Package (Manuals, Component Data Sheets & Warrantees).

General Configuration Notes:

1. System Supply Manifold Assembly is shipped oriented parallel to rear. However, it is field adjustable by combined clockwise rotation of circulator flange & lateral elbow up to 135°. A recommended 45° rotation optimizes appliance compaction, visibility, service access, operation and maintenance. However, the range is available for suitable on-site adjustment.
2. Our heavy cast-iron, steel, brass/bronze construction and Delta-T Management negate the need for boiler return temperature control or magnetite alleviation as recommended with other systems.
3. **No copper fittings are utilized in appliance construction!** This is purposeful to protract appliance service life under poor water supply conditions.
4. All Appliance water terminations are IPS (female threaded pipe) connections. This permits a universal interconnection to a variety of materials and methods at the option of the installer.

IV. Installation:

Installation procedure closely follows the [Weil-McLain Ultra Oil Manual](#) and should be referenced using our hyperlinked (electronic) and their manual copy for on-site work. It would be prudent to read their full introduction (**See Manual, Pages 2 thru 7.**) and location (**See Manual, Pages 8 thru 11.**) segments, making notations prior to proceeding with installation.

NEW: New installations can proceed incrementally and over a period of time, depending upon construction timetables, materials and support task inter-dependencies. Items not covered in our guide such as exhausting, utilities, oil tank & fuel line installs must be executed per State and Local Codes.

REPL: Replacement installations typically vary from well-planned to service demand emergencies and is necessarily the focus of our Planning & Installation Guide. The primary advantage of our product in fact is to optimize TAT (turn-around-time). Ideally the old is coming out while the new is on its way.

Item 1. Exhausting. (See Manual, Pages 12 & 13.)

There is an adage among plumbers – “Big pipes first!” Thus in heating planning, therefore flue exhausting is Task 1. Refer also to commentary in Planning, Page 5. Boiler Manual coverage is too brief and thus we offer more detail.

All of our Delta-T Systems require a 6” dia. X 26 ga. galvanized flue piping at minimum. Stainless 24 ga. flue piping is also available, but at a **substantial** premium (Spl. Order).

REPL Note: If current chimney flue inlet is larger than the 6” dia. the Delta-T System requires, it is **strongly recommended** that it be reduced using a flush, cemented-in-place 6” Thimble! A Flue Increaser adds 2 to 3” or more to chimney offset and provides an accumulation point for fly ash with a subsequent corrosion eventuality.

Minimizing exhaust (flue) piping is very important to maximize efficiency and minimize longer-term operation and maintenance issues. Following are a series of sketches that depict the preferred options and reflect our experiences. They provide both strong and minimally troublesome assemblies. At minimum:

1. Use 90° flue elbows only at boiler exit and chimney entry, if possible.
2. Mount the damper tee vertically, if possible. The tee branch must always be horizontal (to accept the 6” [Barometric Damper](#), supplied). See Instruction Sheet.
3. If an offset is necessary, use a 45° flue elbow (never adjust a 90°) at the boiler end elbow. Rotate the matching upper 90° to align.

4. Avoid horizontal runs on flue piping that accumulate corrosive combustion residue.
5. Secure with #8 x 1/2" Self-Tapping Screws, 3-point radial spacing. **Check Code.**

Fig. 3 - Flue Piping Detail

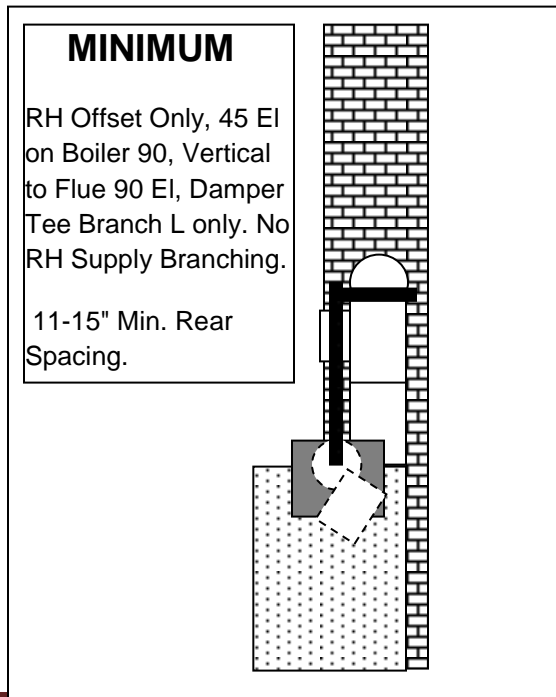
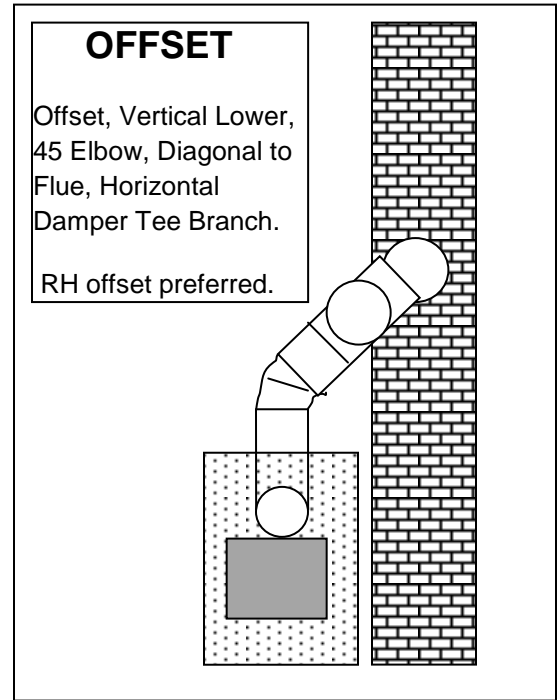
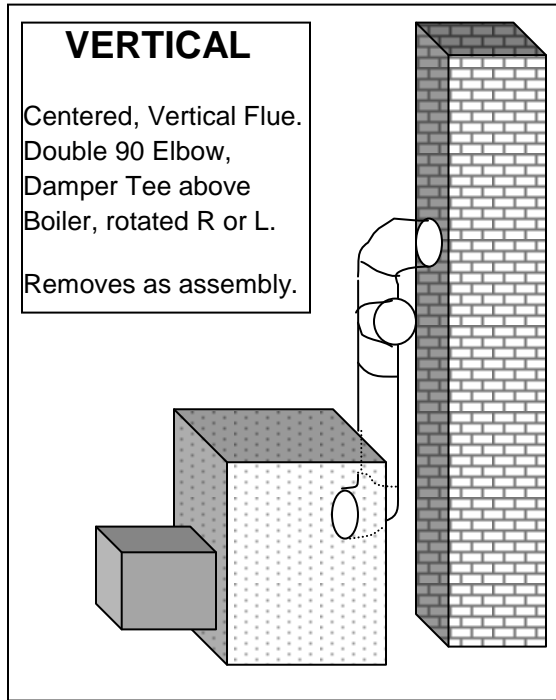

Assembly Notes:

1. Final Level Boiler.
2. Assemble & Orient Boiler & Flue Elbows.
3. Locate & Orient Damper Tee on Flue EI with Branch Horizontal.
4. On MINIMUM, Assemble & Orient 45 Elbow to Vertical.
5. On MINIMUM & VERTICAL Cut & Assemble Vertical Flue Pipe.
6. On OFFSET Cut & Assemble (2) or more Flue Sections with 45 EI Intermediate.
7. Adjust Fits & Final Secure.
8. Install, Level & Secure Barometric Damper per Instructions.

Item 2. Pre-Assembled Manifolds. (See Manual, Page 15.)

Two (2) Manifold Assemblies are provided; a larger L-shaped offset Supply with assembled and wired Zone Valves and a smaller offset Return with ball shutoff valves.

Refer to the Assembly Details, Fig.4 following to locate and assemble these to the Boiler Assembly.

The Return Manifold is positioned first by standing it up on the Boiler Assembly (left rear piping riser) and hand-tightening the union nut. Rotationally orient for best return line routing. Loosen, rotate and align the upper Yoke/Clamp toward the Supply Manifold riser. Remove the other Clamp screw completely and hinge back the clamp arm.

Locate the Circulator Square O-Ring Seal into position on the Circulator Flange (Boiler Assembly, center rear piping & circulator riser). Place the two (2) Circulator Bolts & two (2) Nuts loose on top of the boiler for access ease.

Using two (2) persons, stand the Supply Manifold Valve Flange on the Supply Circulator Flange and Washer. Locate the upper riser pipe into the opened Screw Clamp and employ a second person to loosely re-close the cap and loosely install the screw. Drop the two (2) Circulator Bolts supplied through the valve flange. Locate them through the Circulator Swivel Flange and loosely assemble the two (2) Nuts to hold position.

The Supply Manifold as supplied is oriented toward the right, with both the upper lateral AND the lower Option Ports (for External and/or DHW), parallel to the rear of the boiler. If an alternative orientation is desirable, refer to **Assembly Details, Fig. 5** following for orientation range limits of the upper Supply Manifold (Site dependant)..

Note – The Preferred 45° Option: Rotating the Supply Manifold 45° CW forward (See Prior, Page 14, Figs. 4&5) permits 45° degree fitting utilization, beneficial to both hard piping and flexible tubing utilization. This provides both ideal instrument visibility and service point accessibility. This also applies to the Return Manifold Valves, if necessary.

Note - C, E & T Options: Any further rotation of the lower supply branch fittings must be done with CW (clockwise) or minimal CCW (counter-clockwise) rotation only! Otherwise fitting leakage can result. If not achievable, pipe & fitting reassembly is required.

Once Supply & Return orientations are determined, final assemble as follows:

1. Tighten circulator bolts evenly to full seating. (Note nut-capture flange feature.)
2. Tighten return union securely.
3. Tighten upper yoke assembly screws to securely brace prior to further assembly
4. Tape, dope & assemble Expansion Tank to supply point.

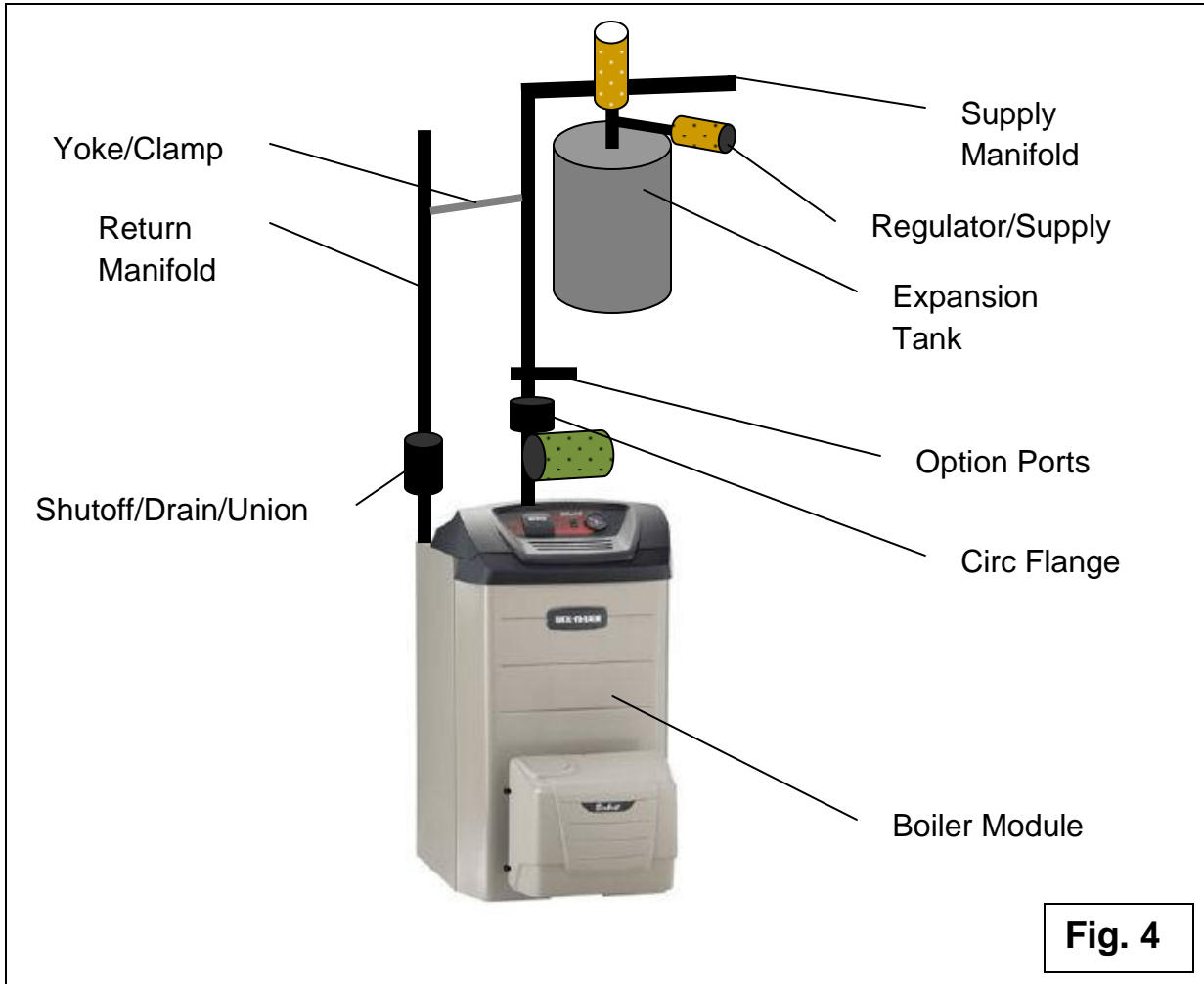

Assembly Details

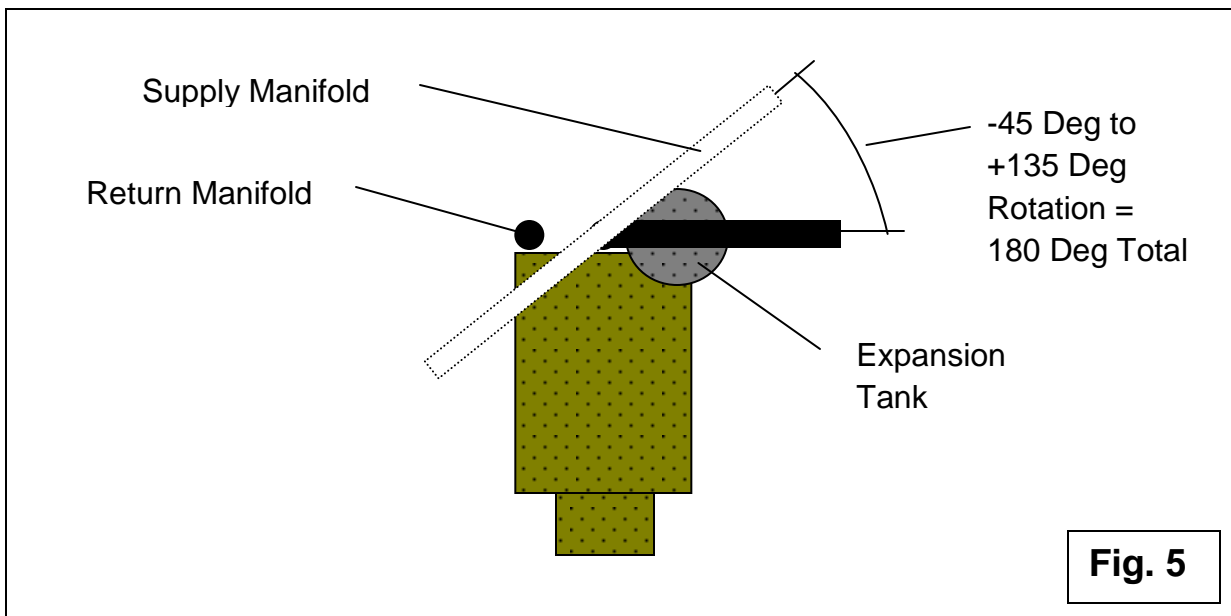

Item 3. Piping Planning & Installation. (See Manual, Pages 15 - 17.)

The Delta-T ECM Appliance is then finish plumbed and wired. Use the W/M Boiler Manual as a Reference Only! Three (3) tasks are required to complete the system plumbing:

1. Provide domestic water service to the boiler.
2. Extend the supply & return zone piping to their respective service points.
3. Attach the fuel line to the pre-valved burner.

Note: The Delta-T ECM Appliance is “water-tight”, as assembled. Water pressure may be added at any point after Return/Supply Manifold & Expansion Tank installation with no consequence. It will completely fill and automatically de-aerate the system up to the zone valves.

REPL: The self-fill and de-aerate system feature can be used to particular advantage when replacing a system by restoring heat to the structure incrementally and rapidly.

All water fittings on the Delta-T System are female threaded pipe (IPS).

1. Boiler Water Pressure Regulator – ½” IPS.
2. Zone Valves & Returns – ¾” or 1” IPS, unless otherwise specified.
3. IWH Valve & Return – 1” IPS **only**. (See IWH Supplier Instructions.)
4. Extension Ports (Plugged) – 1-¼” or 1-½” IPS, same as system supply and return piping sizes, unless otherwise specified.

There are several interconnect options:

1. Copper-To-Male (CMA) Fittings to Copper Piping.
2. [PEX Male Threaded Adapters](#) to [PEX Tubing](#).
3. Additional hard-pipe material options, per client specification and option.

Referring to our prior **Note** on Page 15 and to **Assembly Details, Fig. 5** preceding you will note that the Supply Manifold can be rotated within the range described. Its rotation is limited by the Hydronic Expansion Tank and possibly the Flue Piping (Exhausting) on your particular installation. If this is the case, a ½” B.I. Pipe Street 90°, a Standard 90° and a suitable ½” B.I. Nipple length can be used to alleviate this problem (not supplied). Otherwise substitute a [Floor-Model Expansion Tank](#) (optional).

The recommended orientation was chosen for efficient packaging, serviceability and to limit leakage effects over the life of the system. This **45° CW Rotated Option** is favorable to hard-piping (copper) when using 45° fittings and PEX Tubing in some circumstances. A 45° orientation can save some piping while eliminating those higher

flow resistance 90° elbows in particular. This substantially enhances the convection effect inherent in our Appliance, reducing your energy consumption.

Note: The risk of 45° upward Supply Orientation is to risk leakage onto the boiler from a failing Hydronic Expansion Tank, Air Eliminator or Zone-Valves. In our experience however this risk within our component selections is minimal.

Consider the following items in planning your zoning piping:

1. Tag or label your distribution piping supplies & returns before starting. (We use S1, S2, S3, etc. and R1, R2, R3, etc.)
2. Pipe all your Supplies first. Match each zone valve with its supply pipe and thermostat wire. (Label thermostat wires as T1, T2, T3, etc. to match zones.)
3. Pipe all your Returns next. They can terminate at any Return Manifold port. This also permits selective single or multiple zone plumbing and operation during construction or replacement.

Note: A single drain valve is provided between the Return Manifold and above the Boiler Module Return Isolation Valve for "purging". We employ "negative truth logic", i.e. closing all valves but the desired in performing the "purge" operation.

4. **Indirect Water Heater Option.** If applicable, locate & install the Indirect Water Heater plumbing, referring to its [Installation Manual](#). This must be 1" dia. for proper heater warm-up and recovery. These plumb lower on the boiler as follows:
 - a. The supply line from the branched Zone-Valve above the System Circulator is routed to the upper "BOILER IN" port on the Heater.
 - b. The return line is piped from the lower "BOILER OUT" port on the heater to the valved port at low point of the return riser (near the floor).

Note: A two-wire R-W must later be extended from the Heater Aquastat to the Boiler Terminal Strip. (See Wiring Installation.)

Install a cold water supply to the boiler water service regulator. It would be prudent to install a ball shutoff valve close before the boiler service regulator to facilitate servicing.

While doing this you should consider the [Fire Sprinkler Head](#) option for Code Compliance. Branch it off the site water service supply with a readily accessible shutoff valve for post-emergency shutdown.

Connect the 3/8" Clear Vinyl Tubing between the Backflow Preventer Drain Fitting and the other on the Pressure Relief Valve Tee, cutting length to suit. Visible drain operation is provided while containing possible future water damage.

The Delta-T Appliance is now water-tight and boiler can be filled by opening site service shutoff to Pressure Regulator Assembly. Refer to Weil-McLain Ultra Oil Manual, Page 23, Startup Procedure, "Fill the System" (only) for further detail.

Item 4. On-Site Wiring Installation.

The Delta-T ECM Appliance as supplied is operationally fully wired. It remains only to provide external electrical power service and control interconnects as follows:

1. Connect the heating zone thermostat (R-W) wires to their corresponding Zone-Valves (S1/V1 to T1, S2/V2 to T2, etc.) on Supply Manifold top as follows:

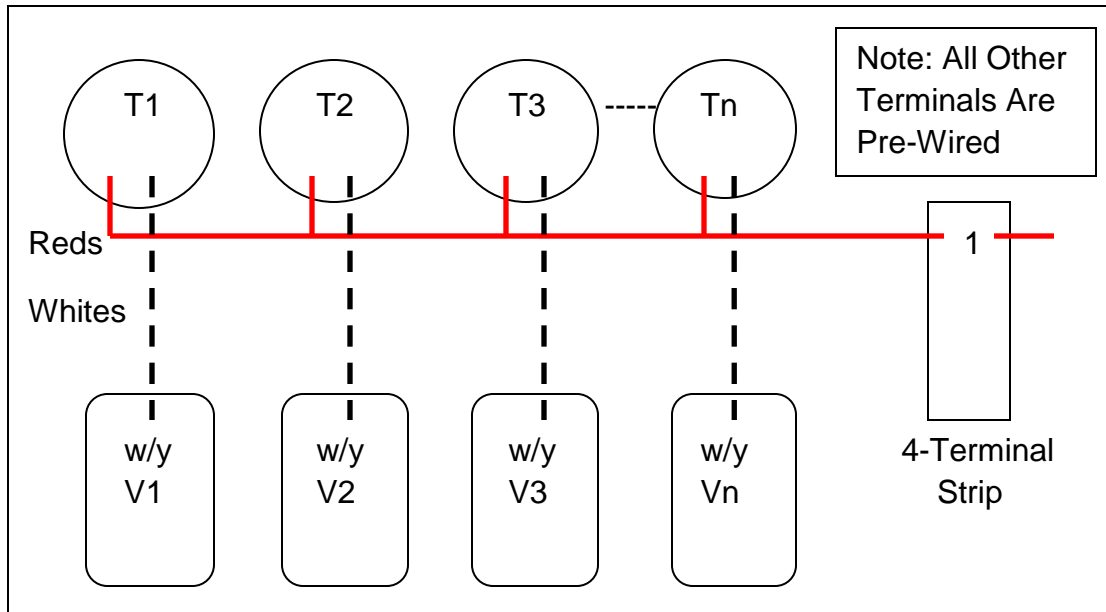

2. Connect the four (4) taped wires extending from the bottom of the Supply Manifold to the side of the Service Switch Assembly 4-Terminal Strip as follows:

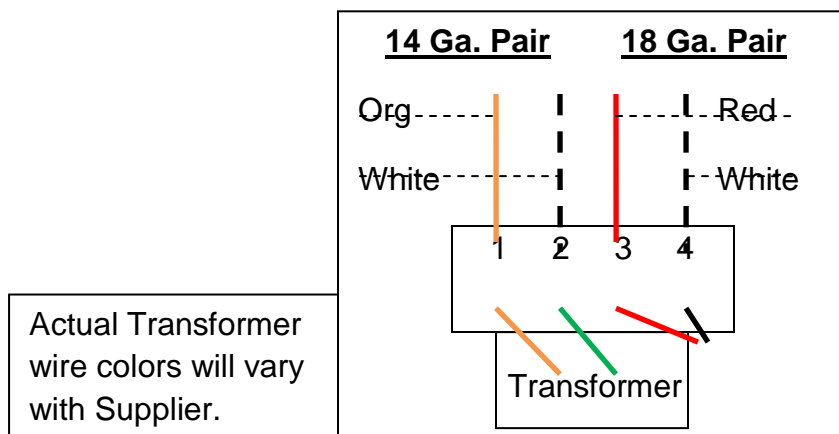

3. System Power Wiring consists of supplying three (3) 14 Ga. B-W-G wires from the Firematic Switch above the boiler area to the Service Switch Assembly. A 1/2" EMT Adapter on top of the Service Switch is provided. It is recommended that 1/2"

EMT Tube be used to route and protect this wiring. The Delta-T Appliance requires a **120 Volt 15 Amp. Maximum Dedicated Circuit Breaker Service**. Refer to Local Codes to verify your service wiring requirements.

Item 5. Fuel Line Installation.

Note: Typically **OIL or GAS** Fuel Line Installations must be performed by a Certified or Licensed Technician, as directed by your respective State and/or Local Codes. **Verify!**

Installing the **OIL or GAS** Burner and the appropriate Fuel Line has been left for last so as to provide space and ease of access in performing the prior operations. However it could be performed at any point after boiler positioning and flue pipe installation.

Refer to the Weil-McLain (Oil) Boiler Manual, Page 30 and remove the Boiler Front Jacket for access. Do similarly with the Carlin Gas Burner Installation Sheet.

Note: We remove the Boiler Cover Securing Screw permanently to facilitate service access, particularly to readily view the new Hydrolevel 3250-Plus Aquastat Display.

Back off the three (3) boiler burner mounting bolts initially with a 5/8" Wrench and then hand-turn outward to about 1/4".

Remove the Beckett NX **OIL** or the Carlin EZ PRO **GAS** Burner from its carton. Grasping it mid-length for balance with the burner tube horizontal, slide the tube into the burner port unit the bolt heads are contacted. Rotate the burner CCW slightly and locate the bolt heads through the "keyhole" slots in the burner flange. Turn the burner CW to lock into place. Tighten the three (3) mounting bolts securely with a wrench.

Plug the burner wiring plug into its mating connector, located on the bottom strap of the boiler enclosure. See Weil-McLain Boiler Manual, Page 19 for visual detail.

OIL Only: A Firematic Oil Valve has been pre-fitted to the Beckett NX Burner. Refer to the Weil-McLain Boiler Manual, Page 22 for additional detail. Position and cut a 3/8" Dia. copper oil line, sleeve the flare nut onto the line, and then flare with appropriate tool. Install the oil line onto the Firematic Valve and tighten securely. Per our initial note however, oil line material coating, on or under-floor routing and protection must comply with your Code(s). Similarly overhead oil line routing must comply.

GAS Only: A valved 1/2" Gas (NG or LP) service line with debris trap must be provided to the Carlin EZ PRO per Instructions. A Licensed Technician is typically required to install a gas service. Check you Locale Code(s)!

Replace the Boiler Front Jacket only after starting and tuning the boiler. Refer to the Weil-McLain Boiler Manual, Pages 23 through 29 to complete the installation.

OIL Only: Remove the Burner Enclosure along with a four (4) Screw-Knob Package from the Burner Carton and lay aside for post-installation/testing assembly.

Item 6. Post-Assembly Insulation (Optional).

“Stand-by” (between cycle) heat losses should be minimized for peak operational efficiency, and particularly when using an Indirect Water Heater for Domestic Hot Water.

The heat-jacketed Weil Boilers do this commendably. They employ a sophisticated [“Cold Start Aquastat”](#) as their Primary Control. The Boiler runs ONLY when there is a heating demand, at an optimum supply temperature and the ideal flow rate provided by the Delta-T Circulator. Otherwise it cools toward ambient temperature, saving energy.

We pre-insulate our Return & Supply Piping as follows:

1. The 1-1/4” or 1-1/2” Boiler Return from Union to Return Tap
2. The 1-1/4” or 1-1/2” Supply vertical stack between fittings.
3. The 1-1/4” or 1-1/2” Supply lateral from the elbow to the Air Eliminator..
4. Note: We insulate only the piping (nipples) and not the fittings.

The Return upper stack is not insulated.

When using an Indirect Water Heater however you have incremental demands year around. Despite typically short and occasional hot water replenishment demands, the “stand-by” losses become proportionally more significant. We HIGHLY RECOMMEND that you further insulate your DHW System as follows:

1. All the 1” piping from the Supply & Return Tees to the Indirect Water Heater boiler water supply points.
2. The Water Heater HOT Outlet & Distribution Lines, as practical.

Note: In all cases use a good quality “made to fit” cellular foam piping insulation. Look to the Trade Supply Houses for these --- you will ultimately save in doing so.

Refer to our [Indirect Water Heater Guide](#) for more detail.

Our Supply Assembly is pre-insulated as supplied. There is little incentive to further insulate your system, save being in an internal or external close space where the ambient temperature becomes obsessive.

There is also the point to be made that uninsulated system piping can be desirable when a boiler resides in a lower, damp area where moisture control can be a factor. It may supplement and reduce the demands upon a dehumidifier.

V. Start-up and Operation:

Refer to the [Weil-McLain Boiler Manual](#), Pages 23 thru 29.

Boiler fill, zone purging, start-up and operation should be performed by a qualified technician.

Additionally the following attributes unique to the Delta-T System must be noted.

1. The Delta-T (ΔT) Differential Temperature as delivered is set at 20°F. Referring to the [Taco® VT2218 Instruction Sheet](#), this value is readily adjusted. See “Programming your VT2218” on Page 5 of Instructions. Caution should be taken when making adjustments to this value however, making small incremental changes and observing resulting operation. This should also be limited to high-demand period adjustment for best results.
2. Make the "No. of Zones" setting on the Aquastat to suit your installation. Do not include the Indirect Water Heater in determining "Zone Count".
3. Refer to the [Weil-McLain Boiler Manual](#), Page 20 Wiring Diagram. The Advanced Features Module (AFM) is not offered or utilized on our Delta-T single boiler systems.
4. The Outdoor Temperature Sensor (ODS) Option is unnecessary and counter-functional within our system.
5. Similarly, further Weil-McLain or other “Boiler Management Systems” are not recommended nor supported.
6. A Zone Valve Controller is not offered or necessary. Status LED’s are featured on the “Zone Sentry” Zone-Valves employed. Further detail is available on the [Taco Zone Sentry Instruction Sheet](#).

Reassemble the Boiler Access Panel and position the Burner Enclosure with the four (4) Knurled Knobs supplied. (You will note a substantial decrease in burner noise level.)

NOTE: A “**User’s Guide including Specialized Service Notes**” is supplied with our Appliances and included in the Document Packet. It is particularly informative to both the user and potential future servicemen. With the exception of the specified Delta-T ECM Circulator and **OIL** Nozzle, standard service procedures apply. Like component product specification replacements are required as needed.

Notes:

A large, empty rectangular box with a thin black border, intended for handwritten or typed notes. It occupies the central portion of the page.